

SIEMENS

Modbus RTU



OpenAir™ VAV Compact Controller Modbus RTU G..B181..MO

Technical Basics

Issued by
Siemens Switzerland Ltd
Smart Infrastructure
Global Headquarters
Theilerstrasse 1a
6300 Zug
Switzerland
Tel. +41 58-724 24 24
www.siemens.com/buildingtechnologies

© Siemens Switzerland Ltd, 2015
Technical specifications and availability subject to change without

Table of contents

1	Introduction.....	4
1.1	Revision history	4
1.2	Before you start	4
1.3	Objectives of this basic documentation.....	5
1.4	Referenced documents	5
2	Device.....	6
2.1	Type summary	6
2.2	Design and device parts.....	9
2.3	Dimensions.....	9
2.4	Human-machine interface	10
2.5	Internal diagrams	12
2.6	Measuring principle.....	13
3	Functionality / application	14
3.1	Fields of application	14
3.2	Application examples	14
4	Electrical and mechanical installation	16
4.1	Mechanical installation / mounting.....	16
4.2	Electrical installation / cabling	17
5	Parameterization and operating modes.....	19
5.1	Settings and user interaction.....	19
5.2	Configuration and maintenance tools	21
5.3	Setting examples	22
6	Engineering and commissioning	26
6.1	Fundamentals / environments	26
6.2	Engineering	26
6.3	Commissioning	26
7	Safety and EMC optimization	28
7.1	Safety notes	28
7.2	Device-specific regulations	29
7.3	Notes on EMC optimization.....	30
8	Technical data.....	31
9	Datapoints and function description	33
9.1	Device Parameters (ACS931 / ACS941 / AST20).....	33
9.2	Modbus Registers.....	34
9.3	Parameter and function description	36
9.4	Object and function priorities.....	39
10	Environmental compatibility and disposal	40

1 Introduction

1.1 Revision history

Version	Date	Changes	Section	Pages
e	2021-10-26	Adaptive positioning	2 Device 6 Parameterization and operating modes 10 Datapoints and function description	11 20 36 38 41
d	2019-09-13	AST22 replaces AST11	2 Device	6
c	2018-04-16	LED colors and patterns updated, internal diagrams	2 Device	10 12
b	2016-02-26	EU and RCM Conformity, European Directive 2012/19/EU	9 Technical data, 11 Environmental compatibility and disposal	32 38
a	2015-07-20			

1.2 Before you start

1.2.1 Trademarks

Trademarks used in this document are listed together with their legal owners below. Use of these trademarks is subject to international and national statutory provisions.

Trademarks	Legal owner
Modbus®	Modbus IDA www.modbus.org/

All the product names listed are trademarks (™) or registered trademarks (®) of their respective owners, as listed in the table. Further to the notes in this section, and to facilitate the reading of the text, these trademarks will not be indicated elsewhere in the text (e.g. by use of symbols such as ® or ™).

1.2.2 Copyright

This document may be duplicated and distributed only with the express permission of Siemens and may be passed only to authorized persons or companies with the required technical knowledge.

1.2.3 Quality assurance

These documents were prepared with great care.

- The contents of all documents are checked at regular intervals.
- Any corrections necessary are included in subsequent versions.
- Documents are automatically amended as a consequence of modifications and corrections to the products described.

Please make sure that you are aware of the latest document revision date.

If you find lack of clarity while using this document, or if you have any criticisms or suggestions, please contact your local point of contact in your nearest branch office. The addresses of the Siemens regional companies are available at www.siemens.com/sbt.

1.2.4 Document use / request to the reader

Before using our products, it is important that you read the documents supplied with or ordered at the same time as the products (equipment, applications, tools etc.) carefully and in full.

We assume that persons using our products and documents are authorized and trained appropriately and have the technical knowledge required to use our products as intended.

Siemens assumes no liability to the extent allowed under the law for any losses resulting from a failure to comply with the aforementioned points or for the improper compliance of the same.

1.3 Objectives of this basic documentation

This basic documentation covers the networked VAV Compact Controllers G..B181..MO. These devices are designed for controlling variable or constant air volume flows.

1.4 Referenced documents

- [1] G..B181..MO - VAV Compact Controllers Modbus RTU - Datasheet (A6V10631832)
- [2] Mounting instruction for VAV Compact Controllers (A6V10523083)
- [3] AST20 - VAV Handheld Tool - Datasheet (A6V10631836)
- [4] AST22 - Interface converter (A6V11236956)
- [5] ACS931 - PC-Software for OEM - Datasheet (N5853)
- [6] ACS941 - PC-Software for Service - Datasheet (N5854)
- [7] Modbus over serial line - Specification and Implementation Guide (www.modbus.org)

2 Device

2.1 Type summary

2.1.1 Device variants, tools and accessories

VAV Compact Controller Modbus RTU

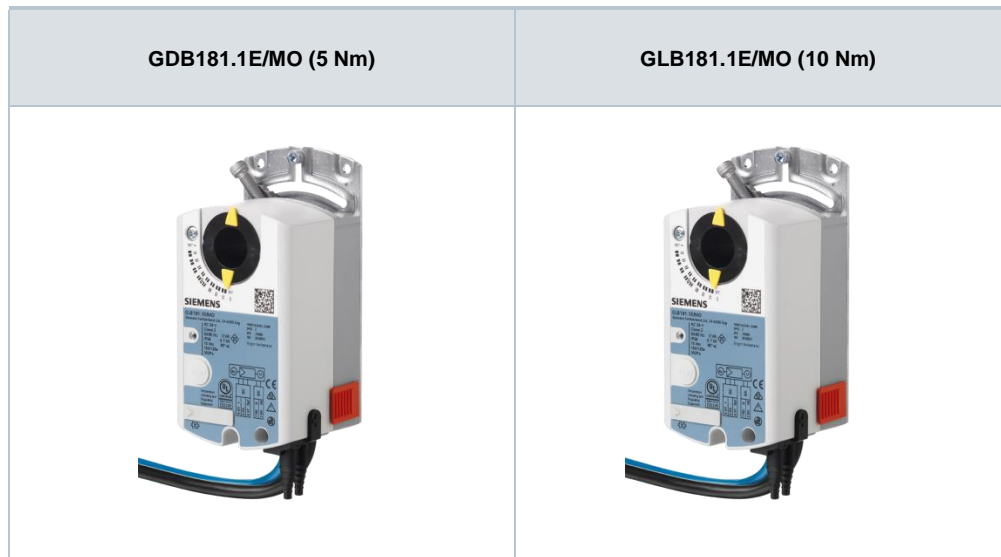

Tools for commissioning and service

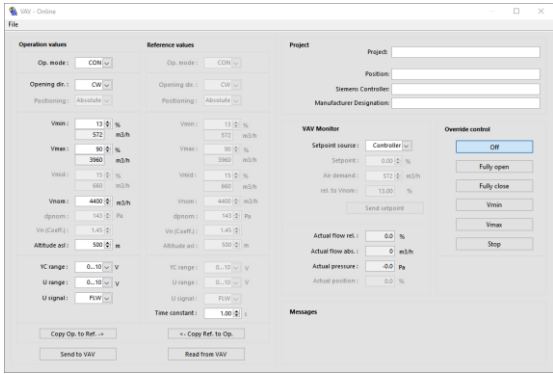
AST20	ACS931 / ACS941
	
<p>The handheld tool AST20 can be used for status monitoring, VAV parameter setting, and bus configuration setting.</p>	<p>The PC software for service ACS941 can be used for setting and reading a certain set of device parameters (values set by OEM and current configuration, and actual values).</p> <p>For connecting to a PC with RS232 interface, an interface converter AST22 is required.</p>
<p>Datasheet: A6V10631836</p>	<p>Datasheet ACS931: N5853 / ACS941: N5854 Datasheet AST22: A6V11236956</p>

Accessories

For information regarding accessories and spare parts for VAV Compact Controllers, please refer to datasheet N4698.

2.1.2 Selection guide for all types

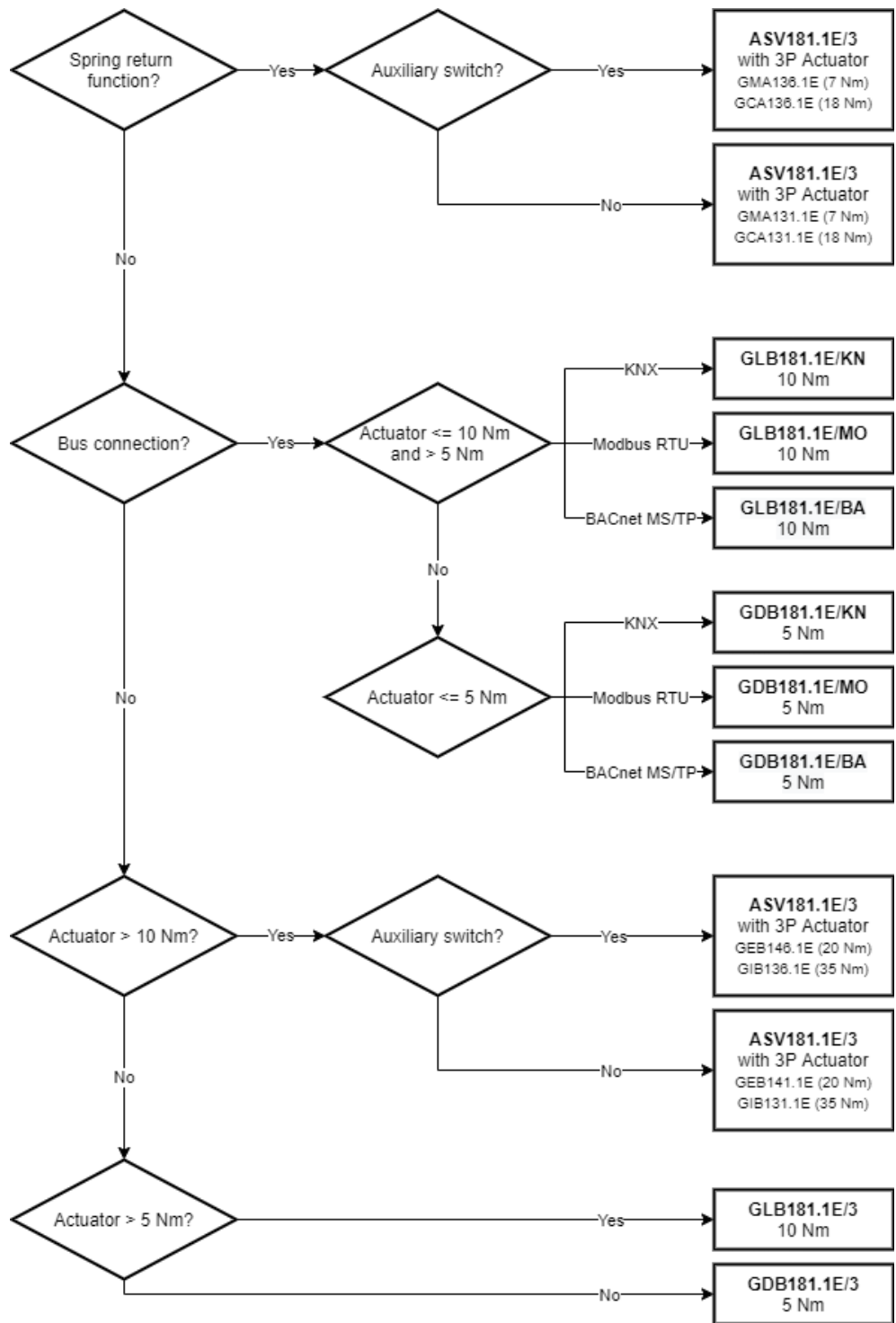

2.1.3 Version summary

The production series can be identified by the letter behind the code “2PFS”.

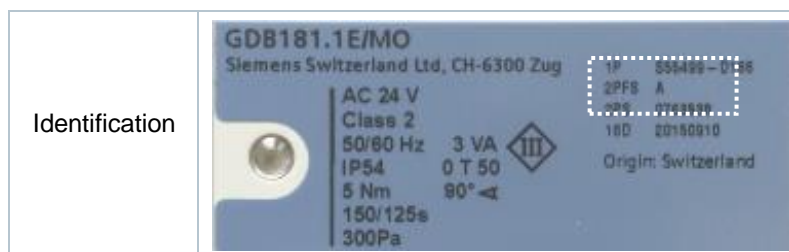

Version	Production time	Features
Series A	Until Sept. 2017	<ul style="list-style-type: none"> ▪ Communication Modbus RTU ▪ Quasi-static differential pressure sensor. ▪ Simultaneous feedback of actual values of damper position and air volume flow. ▪ Optional adaptive opening range measurement (adaptive positioning). ▪ HMI with push button and LED.
Series B	From Sept. 2017	<ul style="list-style-type: none"> ▪ Hardware changes ▪ LED color for bus traffic changed from orange to green

2.2 Design and device parts

The VAV Compact Controllers consist of a differential pressure sensor, actuator and digitally configurable control electronics. They are intended for mounting on damper shafts of a minimum length of 30 mm. They consist of base and 2-sectional housing.

Components contained in the **base**:

- Steel base plate with damper drive shaft fixing for different drive shaft diameters / cross-sectional areas (cf. section 2.3) and angular rotation limiter,
- maintenance-free, low-noise gear train,
- magnetic hysteresis clutch with practically contact-free force transmission; this means that the actuator is locking- and overload-proof, also in continuous operation.

Components contained in the **housing** (Note: the housing cover can't be removed):

- controller electronics,
- differential pressure sensor,
- synchronous motor for the damper actuator.

Main device parts

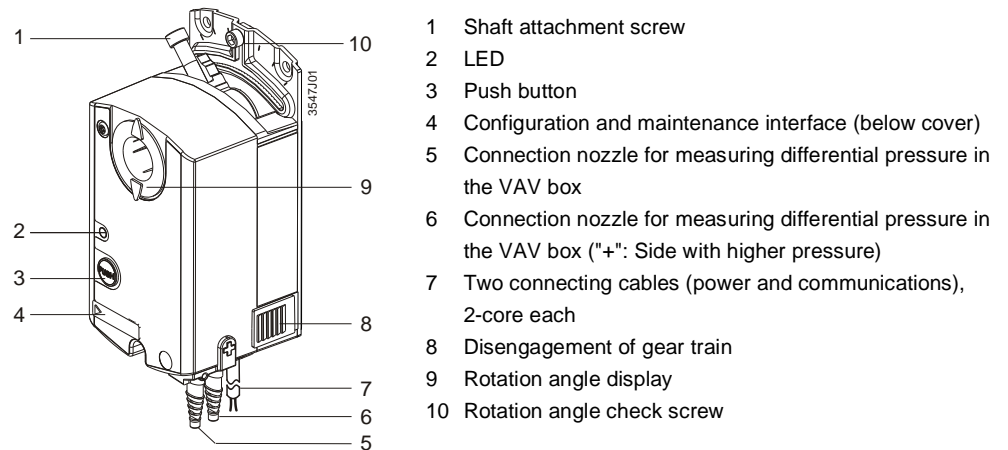

Gear train disengagement

Manual control of the air dampers is possible by gear train disengagement (8) when the VAV Compact Controller is disconnected from the power supply.

2.3 Dimensions

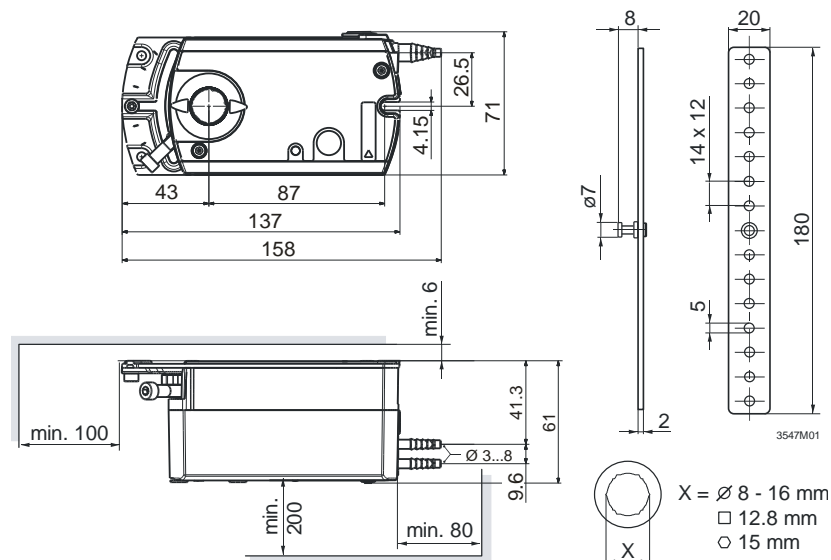

2.4 Human-machine interface

2.4.1 HMI parts and description

Push button operations

Activity	Push-button operation	Confirmation
Display current address (in backward order)	Press button < 1s	Current address is displayed
Enter push-button addressing mode	Press button > 1s and < 5s	Red LED shines (release button before LED gets dark)
Reset to OEM default settings	Press button > 10s	Orange LED flashes

LED colors and patterns

Color	Pattern	Description
Green	steady	Start-up
	1s on 5s off	Fault free operation ("life pulse")
	flashing	Bus traffic ¹⁾
Orange	steady	Device is in on-event addressing mode
	1s on 5s off	Backup mode entered
Red	steady	Mechanical fault / device jammed
	flashing fast	Sensor error: Pressure tubes interchanged or „Invalid configuration“
	flashing slowly	Sensor error: Internal read error
	1s on 5s off	Internal error

¹⁾ LED color is orange flashing for devices from Rev. A, cf. 1.1

2.4.2 Factory reset

Factory reset

The VAV Compact Controllers can be reset by push-button:

1. Press button for >10s → LED starts flashing **orange**
2. Release button while LED still flashes → LED keeps flashing for 3s
3. After those 3s → LED shines **red** (reset), then **green** (start-up).

A factory reset by push-button leads to a reset of all parameters as described in the section 5.1 to the OEM default values. Since these values can be set by the OEM, they are not necessarily the same as the Siemens factory settings.

All other parameters, especially the bus parameters, are reset to Siemens factory settings.

VAV Compact Controllers can also be reset by the VAV handheld tool AST20 or over bus. Please refer to the corresponding operating manual / technical basics.

2.4.3 Addressing by push-button

The bus address (RS-485) can be set without a separate tool by using the push-button and LED. For instructions on setting VAV and communication parameters with configuration and maintenance tools, cf. section 5.1.2.

Display current address.
(digits in reverse order)

To display the current address, press button <1s.

Colors		
1-digits: red	10-digits: green	100-digits: orange
Example for address 124:		
LED		
Note	The address is entered and shown in reverse order.	

Set new address

1. **Enter addressing mode:** press button > 1s until LED shines **red**, then release button (before LED gets dark).
2. **Enter digits:** press button n-times → LED flashes per button press (feedback).
- Colors: 1-digits: **red** / 10-digits: **green** / 100-digits: **orange**
3. **Store digits:** hold button pressed until LED shines in color of following digits – release button,
4. **Save whole address:** hold button pressed until LED shines **red** (address confirmation) → release button.
- If the button is released before the LED shines **red**, the address is discarded.
- An address can be stored at any time, i.e. after setting the 1-digits, or after setting the 1- and the 10-digits.
5. Entered address is repeated one times for confirmation.

Examples

Set address “124”:

1. Enter addressing mode
2. Set 1-digits: Press button 4-times → LED flashes **red** per button press
3. Store 1-digits: press button until LED shines **green** – release button
4. Set 10-digits: Press button 2-times → LED flashes **green** per button press
5. Store 10-digits: press button until LED shines **orange** – release button
6. Set 100-digits: Press button 1-times → LED flashes **orange** per button press
7. Store address: press button until LED shines **red** – release button
→ address is stored and displayed 1x for confirmation.

Set address “50”:

1. Enter addressing mode
2. Skip 1-digits: Hold button pressed until LED shines **green** – release button
3. Set 10-digits: Press button 5-times → LED flashes **green** per button press
4. Store address (skip 100-digits): hold button pressed until LED shines **red** – release button
→ address is stored and displayed 1x for confirmation.

Set address “9”:

1. Enter addressing mode
2. Set 1-digits: Press button 5-times → LED flashes **red** per button press
3. Store address: press button until LED shines **red**
→ address is stored and displayed 1x for confirmation.

2.5 Internal diagrams

The VAV Compact Controller is supplied with two prewired connecting and communication cables.

Internal diagram

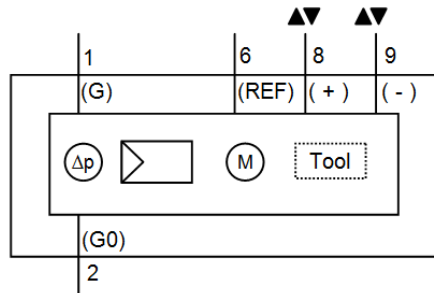

Tool = Configuration and maintenance interface (7-pin)

Power supply and bus cable (color coded and labeled)

Core designation	Core color	Terminal code	Description
Cable 1: Power / black sheathing			
1	red (RD)	G	System voltage AC 24 V
2	black (BK)	G0	System neutral AC 24 V
Cable 2: Communication / blue sheathing			
6	violet (VT)	REF	Reference
8	grey (GY)	+	Bus (Modbus RTU)
9	pink (PK)	-	Bus (Modbus RTU)

Note

Terminal layout may differ for each device. Devices with twin-terminals or internally connected terminals may be encountered as well as bus connection in junction boxes.

- The operating voltage at terminals G and G0 must comply with the requirements under SELV or PELV.
- Safety transformers with twofold insulation as per EN 61558 required; they must be designed to be on 100 % of the time.

2.6 Measuring principle

A measuring device for acquiring the differential pressure – usually a measuring cross, measuring orifice or Venturi tube in the airflow – represents the basis for air volume flow measurement.

Differential pressure sensor

The air volume flow is measured indirectly with a differential pressure sensor. Since the measured value is the differential pressure Δp , the air flow is derived from this value using the VAV box characteristic. Accordingly, the VAV box OEM has to provide the combination of Δp_{nom} and V_{nom} , out of which the air volume flow in m^3/h or l/s can be calculated.

The air volume flow value (relative or absolute) can be transmitted over the bus together with the actual value of the damper position (in %) to be used by a supervisory controller or for management purposes. The differential pressure sensor operates long-term stable and without recalibration.

Note

In critical cases material compatibility tests should be made while considering harmful substances and concentrations.

Setting the characteristic value V_n

The parameter V_n is used to adjust the operating range of the differential pressure sensor (0...300 Pa) to the actual VAV box nominal pressure Δp_{nom} at the factory. The effect of V_n is illustrated in the diagram below.

Effect of V_n

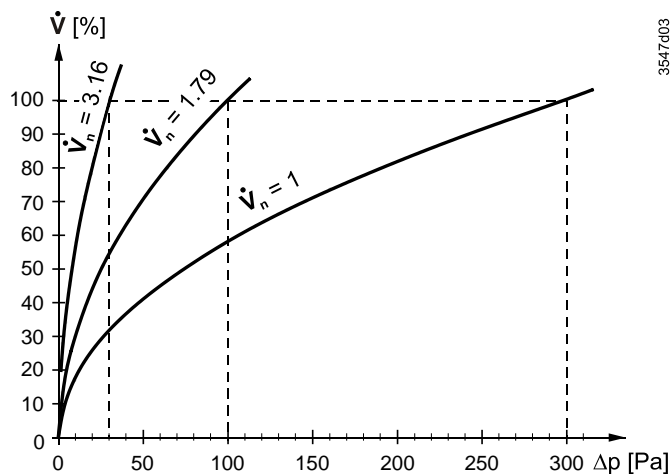

Calculation of V_n
(Δp_{nom} = nominal differential pressure)

$$V_n = \sqrt{\frac{300 [Pa]}{\Delta p_{nom} [Pa]}}$$

Calculation example

Assume that a VAV box is designed for a nominal pressure of $\Delta p_{nom} = 120$ Pa. Then V_n must be set to 1.58:

$$V_n = \sqrt{\frac{300 Pa}{120 Pa}} = 1.58$$

3 Functionality / application

3.1 Fields of application

Application

VAV Compact Controllers are primarily used for controlling a variable or constant air volume flow.

System environments:

- Building automation systems using Modbus RTU (third-party integration and freely programmable devices)

Application fields:

- Supply air control
- Extract air control
- Supply/extract cascade control with
 - Ratio control 1:1
 - Ratio control (positive/negative pressure)
 - Differential control (positive/negative pressure)
- Air dampers with a nominal torque of up to 5 or 10 Nm

Note

VAV Compact Controllers are not suitable for environments where the air is saturated with sticky or fatty particles or contain aggressive substances.

3.2 Application examples

VAV Compact Controllers can be used in supply air and in supply / extract air control applications. Demand-controlled ventilation (DCV) is possible when a communication link to the supply / extract air fans of the air-handling unit (AHU) is established, and the AHU controller offers the required control algorithm.

3.2.1 Supply and extract air control

Supply / extract air control

If one VAV Compact Controller is used for supply air and one for extract air, these are usually controlled individually by the supervisory controller. By setting their volume flow limits (V_{min} and V_{max}) according to the setting instructions in section 0, constant, positive, or negative pressure in a zone or a room can be achieved. When omitting the extract air part, a simple supply air control application can be realized. Disadvantages are that ventilation conditions in the room or zone can't be controlled precisely.

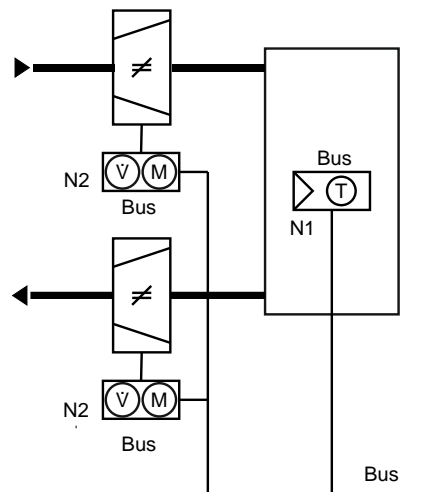

Legend:

- Bus Fieldbus (Modbus, BACnet, KNX etc.)
- N1 Room unit with temp. sensor
- N2 VAV Compact Controllers (supply air / extract air)

3.2.2 Demand-controlled ventilation (DCV)

Example: AHU control optimization

In combination with a suitable supervisory room controller, an AHU control optimization algorithm can be run using the actual value of the damper position feedback signal.

The control of variable speed drives (VSDs) can be accomplished by various means. Below depicted is DC 0...10 V control, but plants with Modbus RTU- or BACnet MS/TP-controlled VSDs are also possible, depending on the connector layout of the universal / primary controller.

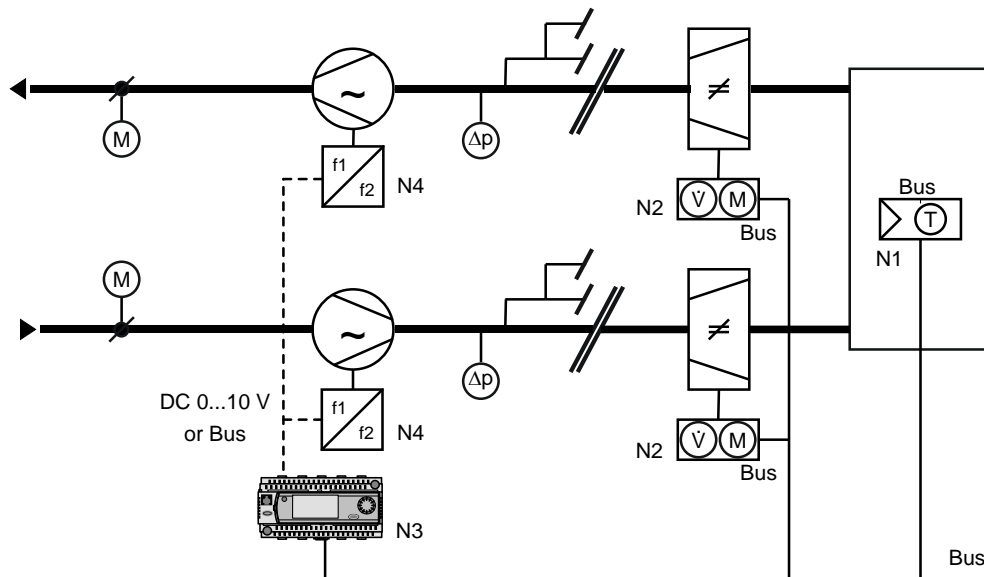

Legend:

- Bus Fieldbus (Modbus, BACnet, KNX etc.)
- N1 Room unit with temp. sensor
- N2 VAV Compact Controllers (supply / extract air)
- N3 Universal / primary controller
- N4 Variable Speed Drives (VSD)

4 Electrical and mechanical installation

4.1 Mechanical installation / mounting

Mounting and mounting limitations

For mounting and limitations on mounting (location / position), consulting the mounting instruction [2] is mandatory.

Environmental conditions

The permissible ambient temperature and ambient humidity must be observed (cf. chapter 8).

Manual control

The actuator may only be manually operated when **separated from power supply**.

Mechanical limitation of angular rotation

If required, the angular rotation can be set by appropriate adjustment of the adjusting screw.

Configuration and maintenance interface

Connection of PC tool ACS931 / ACS941 to G..B181..

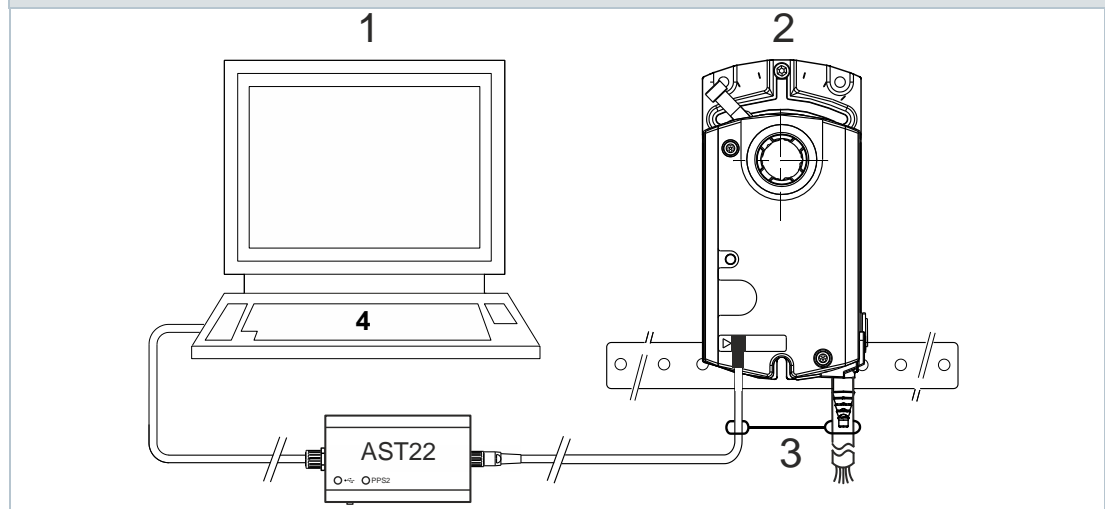

- 1 PC (with ACS931 or ACS941)
- 2 G..B181..
- 3 Strain release strip

Connection of VAV handheld tool AST20 to G..B181..

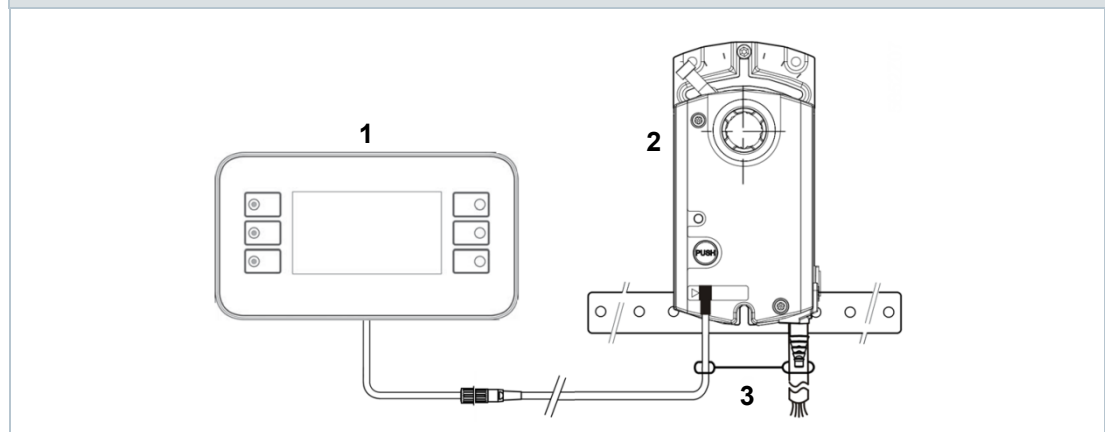

- 1 AST20
- 2 G..B181..
- 3 Strain release strip

4.2 Electrical installation / cabling

4.2.1 Power supply cabling

Permissible cable lengths and cross-sectional areas

The permissible cable lengths and cross-sectional areas depend on the actuators' current draw and the voltage drop on the connecting lines to the actuators. The necessary cable lengths can be determined from the following chart or with the help of the formulas. Cf. also to technical data in section 8.

Note

When determining the cable length and the cross-sectional area, it is to ensure that the permissible tolerances of the actuators' operating voltage are adhered to, in addition to the permissible voltage drop on the power supply and signal lines (see table below).

Permissible voltage drop

The cables are to be sized depending on the type of actuator used and based on the following data:

Type	Operating Voltage	Line	Max. permissible voltage drop
GDB181.. / GLB181..	AC 24 V	G0, G	System voltage AC 24 V

Note

The power supply voltage drop at AC 24 V must not exceed 8 % (4 % over the G0).

L/P chart for AC 24 V

The chart below applies to AC 24 V operating voltage and shows the permissible cable length **L** as a function of power **P**, and the cross-sectional areas as a parameter.

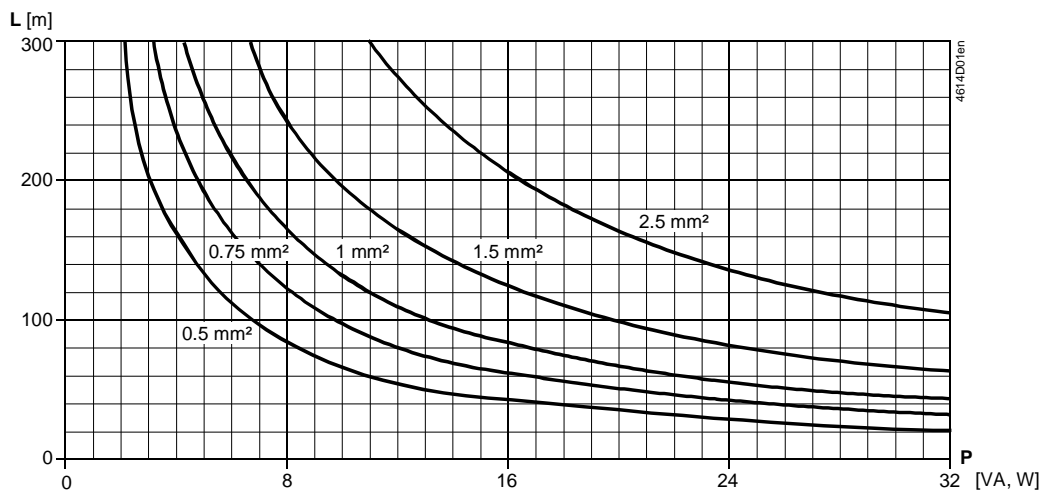

Note on chart

The values in [VA, W] on the P-abcissa are allocated to the permissible voltage drops ($\Delta U/2U = 4\%$) on line length L as per the above table and the basic diagram.

P is the decisive power consumption of all actuators connected in parallel.

Basic diagram:
Voltage drop on the supply lines

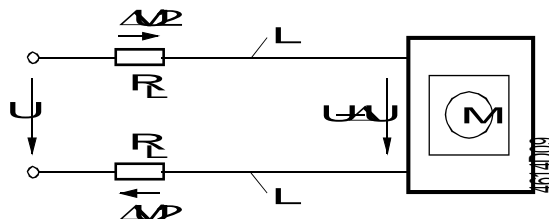

Formula for cable length

The following formula can be used to calculate the maximum cable lengths.

Operating Voltage	Permissible voltage drop	Formula for cable length
AC 24 V	4 % of AC 24 V	$L = \frac{1313 \cdot A}{P}$ [m]

- A Cross-sectional area in [mm²]
- L Permissible cable length in [m]
- P Power consumption in [VA] or [W]; refer to the actuator's type field

Example: Power consumption and permissible voltage drop (1 VAV controller)

Operating Voltage	Power consumption	Perm. voltage drop for line... 1 (G), 2 (G0)
AC 24 V	3 VA	4 % of AC 24 V

Example: Parallel connection of 4 actuators

Determine the cable lengths for 4 actuators operating on AC 24 V. Decisive for sizing the cable are only the AC currents on lines 1 (G) and 2 (G0). Maximum permissible voltage drop = **4 % per line**.

- Consumption = 4 x 3 VA = 12 VA
- Line current = 4 x 0.125 A = 0.5 A

Permissible single cable length for G and G0:

- 164 m with a cross-sectional area of 1.5 mm²
- 274 m with a cross-sectional area of 2.5 mm²

4.2.2 Bus cabling

Instructions regarding topology and addressing in Modbus RTU networks can be found in [7]. The following sections presuppose electrical installations that conform to the protocol-specific requirements.

5 Parameterization and operating modes

5.1 Settings and user interaction

5.1.1 Device parameters

Parameterization

The OEM generally provides the basic configuration to VAV Compact Controllers, esp. the parameters V_n and V_{nom} . The basic configuration is independent of the system environment where the VAV Compact Controllers are to be used.

For parameter setting, configuration and maintenance tools as described in section 5.1.2 are available. The following parameters must be checked or set prior to commissioning and be documented in the plant documentation. Please refer to section 9.3 for more explanation.

Parameter	Range	Description	Factory setting
Operating mode	VAV (flow ctrl.) / POS (position ctrl.)	Interpretation of setpoint VAV = Setpoint controls volume flow [%] POS = setpoint controls damper position [%]	VAV
Opening direction	CW (R) / CCW (L)	Opening direction of air damper	CW (R)
Adaptive positioning	Off / On	Adaption of actual opening range to position feedback ¹⁾ Off = mapping 0°...90° → 0..100 % On = mapping e.g. 0°...60° → 0..100 %	Off
V_{max}	20...120%	Maximum air volume flow	100 %
V_{min}	-20...100%	Minimum air volume flow	0 %
V_{nom}	0...60'000 m ³ /h	Nominal air volume flow ²⁾	100 m ³ /h
V_n	1.00...3.16	Characteristic value for the air volume flow; set by the manufacturer (OEM)	1.00
Altitude	0...5000m in 500m steps	Altitude level correction factor for differential pressure sensor (select n*500m value closest to real altitude)	500 meters

¹⁾ Adaptation must not be activated while a device jam is present

²⁾ Value used for displaying / not used for volume flow control loop

Variable air volume control (VAV)

VAV Compact Controllers operate in VAV mode when connected to the specified power supply. The setpoint signal determines the operating range $\dot{V}_{min} \dots \dot{V}_{max}$.

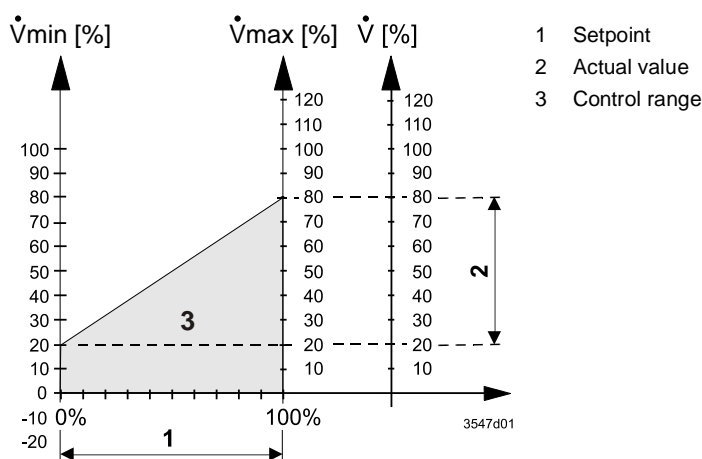

Constant air volume control (CAV)

The VAV Compact Controllers can be operated in CAV mode by setting the supervisory controller to send a constant setpoint.

Position control

VAV Compact Controllers can also be operated as damper actuators, i.e. the 0...100% setpoint is interpreted as position setpoint.

5.1.2 Calculation formulas

The parameters are based on the following formulas:

Calculation of V_n
(Δp_{nom} = nominal
pressure)

$$V_n = \sqrt{\frac{300 [Pa]}{\Delta p_{nom} [Pa]}}$$

300 Pa is the upper limit of the operating range of the differential pressure sensor.
The nominal pressure is the differential pressure in the VAV box at a given nominal
volume flow, determined by the OEM specification.

Min. and max. volume
flows (V_{min} / V_{max})

$$V_{min} [\%] = \frac{\text{min. volume flow [m}^3/\text{h]}}{\text{nom. volume flow [m}^3/\text{h]}} \cdot 100\%$$

$$V_{max} [\%] = \frac{\text{max. volume flow [m}^3/\text{h]}}{\text{nom. volume flow [m}^3/\text{h]}} \cdot 100\%$$

Actual relative flow as
function of setpoint and
min. / max. limits

$$FLW [\%] = \frac{\text{Setpoint [\%]} \cdot (V_{max} - V_{min}) [\%]}{100\%} + V_{min} [\%]$$

Actual relative flow as
function of differential
pressure

$$FLW [\%] = 100\% \cdot V_n \cdot \sqrt{\frac{\Delta p [Pa]}{300 [Pa]}}$$

Actual differential
pressure as function of
actual flow

$$\Delta p [Pa] = 300 Pa \cdot \left(\frac{FLW [\%]}{100\% \cdot V_n} \right)^2$$

5.1.3 Conversion of C-values into V_n values

In case the C-value of a VAV box is known, it can be converted into a
corresponding V_n value as both are linked by Δp_{nom} .

Formulas are linked by
 Δp_{nom}

$$\dot{V}_{nom} = C \cdot \sqrt{\Delta p_{nom}} \text{ and } V_n = \sqrt{\frac{300 [Pa]}{\Delta p_{nom} [Pa]}} \rightarrow V_n = C \cdot \frac{\sqrt{300 [Pa]}}{\dot{V}_{nom}}$$

Example for a box with $C = 57.2$ and $V_{nom} = 900$ m³/h:

$$V_n = C \cdot \frac{\sqrt{300 [Pa]}}{\dot{V}_{nom}} = 57.2 \frac{[m^3/h]}{[\sqrt{Pa}]} \cdot \frac{\sqrt{300 [Pa]}}{900 [m^3/h]} = 1.1$$

In this case, set $V_n = 1.1$ which corresponds to a $\Delta p_{nom} = 248$ Pa.

5.2 Configuration and maintenance tools

Configuration and maintenance of VAV Compact Controllers can be accomplished with the following tools:

- Using the PC software ACS941 or ACS931 together with the interface converter AST22 via the configuration and maintenance interface of the VAV Compact Controller or
- Using the handheld tool AST20.

5.2.1 PC software ACS941 and ACS931

Areas of use

The PC software ACS941 is designed for service and maintenance staff and is used for setting and displaying the parameter values on a PC. Instructions for use of this software can be found in [6].

The PC software ACS941 allows to set or to display the parameters as listed in section 5.1. The software supports trend functions and allows comparing the values set by the OEM with the values currently stored in the device. Thus, changes by parties other than the OEM can be detected.

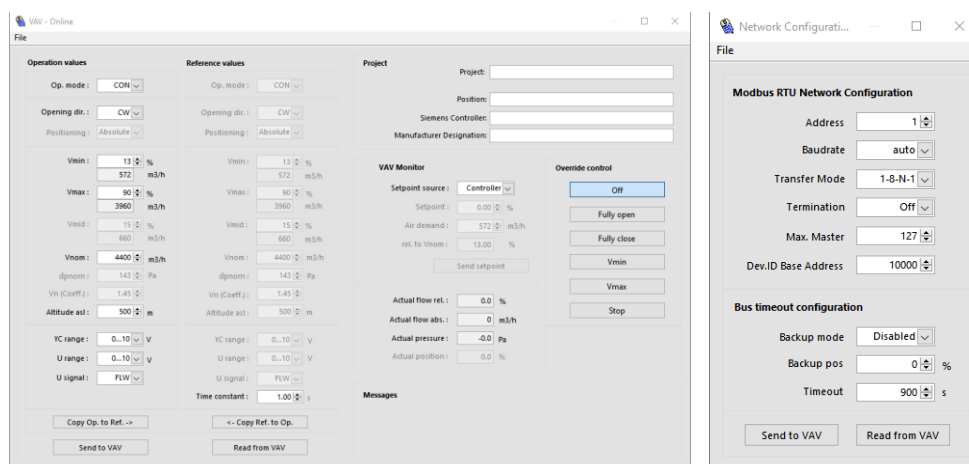

Figure 1: ACS941 with VAV (left) and network (right) configuration pane

Next to the PC software ACS941, an OEM version ACS931 with extended functionality is available as well. ACS931 allows OEM read/write access to all operation and reference values. Its distribution is therefore restricted to OEM customers. For more details, see [5].

5.2.2 Handheld tool AST20

Functionality

Using the handheld tool AST20, VAV and communication parameters can be set or retrieved. Instructions for the use of the AST20 can be found in [3].

Design

The AST20 is designed for portable use on-site. Power supply and establishing the communication between AST20 and a VAV Compact Controller are realized with a 3-core connection cable.

5.3 Setting examples

5.3.1 Symbols and parameters

Volume symbols with “point” (\dot{V}) and without point (V) shall have the same meaning, i.e., they all shall refer to volume flows.

Legend to the setting examples

\dot{V}	Volume flow [%]
\dot{V}_{\min}	Minimum volume flow [%]
\dot{V}_{\max}	Maximum volume flow [%]
$\dot{V}_{\text{supply_air}}$	Volume flow of supply air controller [%]
$\dot{V}_{\text{extract_air}}$	Volume flow of extract air controller [%]
\dot{V}_{master}	Volume flow of supply air controller (Master) [%]
\dot{V}_{slave}	Volume flow of extract air controller (Slave) [%]

5.3.2 Min/max control by the supervisory controller

When setting the minimum / maximum air volume flow in the supervisory controller, the VAV Compact Controller has to be configured with $\dot{V}_{\min} = 0\%$ and $\dot{V}_{\max} = 100\%$.

Setting example A1

VAV ratio control 1 : 1

	Supply air		Extract air	
	Vmin	Vmax	Vmin	Vmax
Supervisory controller	20 %	80 %	20 %	80 %
VAV Compact Controller	0 %	100 %	0 %	100 %

Reference signal: $Y_{\text{supply_air}} = Y_{\text{extract_air}} = 35\%$

Result: $V_{\text{supply_air}} = V_{\text{extract_air}} = 35\%$

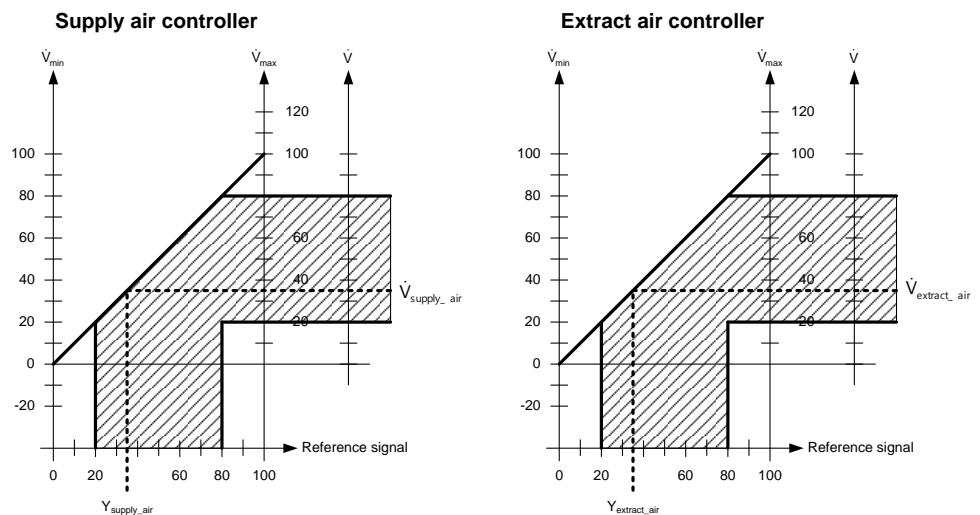

Setting example A2

VAV ratio control, 20 % constant excess supply air volume flow (positive pressure in the room)

	Supply air		Extract air	
	Vmin	Vmax	Vmin	Vmax
Supervisory controller	20 %	80 %	0 %	60 %
VAV Compact Controller	0 %	100 %	0 %	100 %

Reference signal: $Y_{\text{supply_air}} = 35 \%$, $Y_{\text{extract_air}} = Y_{\text{supply_air}} - 20 \% = 15 \%$

Result: $V_{\text{supply_air}} = 35 \%$, $V_{\text{extract_air}} = 15 \%$

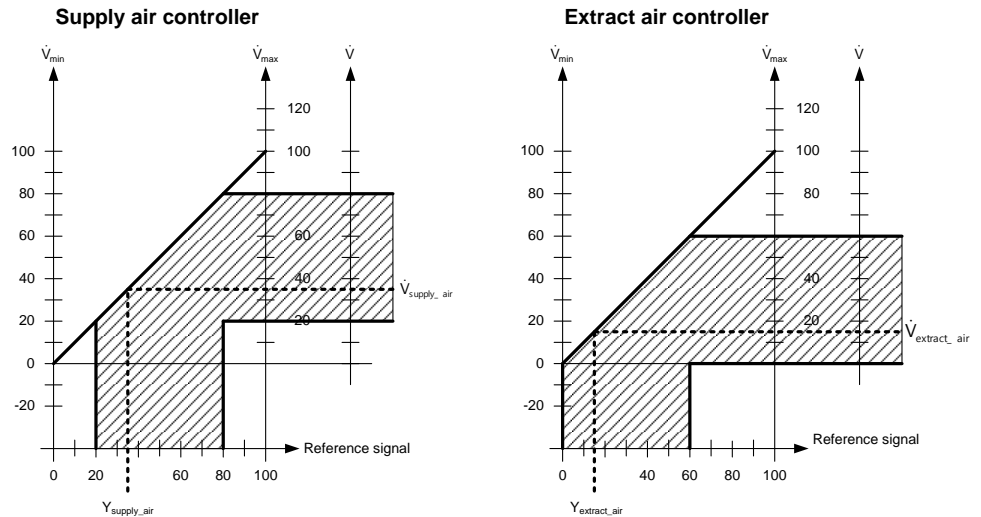

Setting example A3

VAV ratio control, 20 % constant excess extract air volume flow (negative pressure in the room)

	Supply air		Extract air	
	Vmin	Vmax	Vmin	Vmax
Supervisory controller	20 %	80 %	40 %	100 %
VAV Compact Controller	0 %	100 %	0 %	100 %

Reference signal: $Y_{\text{supply_air}} = 35 \%$, $Y_{\text{extract_air}} = Y_{\text{supply_air}} + 20 \% = 55 \%$

Result: $V_{\text{supply_air}} = 35 \%$, $V_{\text{extract_air}} = 55 \%$

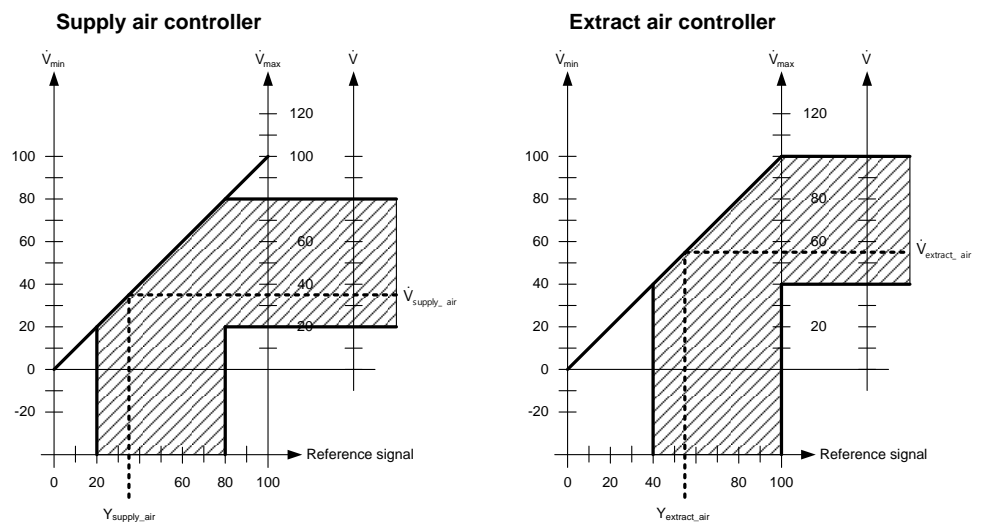

5.3.3 Min/max control by the VAV Compact Controller

When setting the minimum / maximum air volume flow in the VAV Compact Controller, the supervisory controller must be set to $V_{min} = 0\%$ and $V_{max} = 100\%$. With this setting, the supervisory controller reference signal for both the supply air and extract air controller is the same. Thus, supply air / extract air control with a single reference signal is possible.

Setting example B1

VAV ratio control 1 : 1

	Supply air		Extract air	
	Vmin	Vmax	Vmin	Vmax
Supervisory controller	0 %	100 %	0 %	100 %
VAV Compact Controller	20 %	80 %	20 %	80 %

Reference signal: $Y_{supply_air} = Y_{extract_air} = 25\%$

Result: $V_{supply_air} = V_{extract_air} = 35\%$

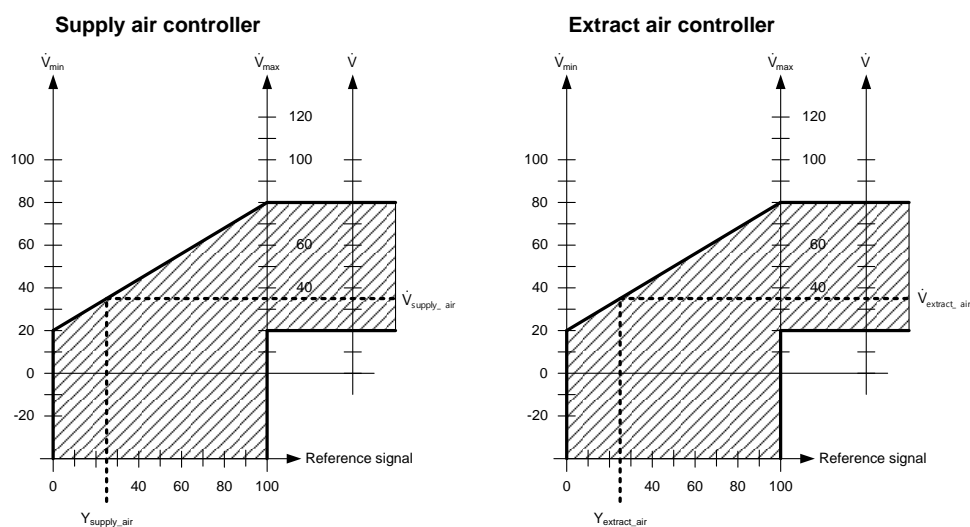

Setting example B2

VAV ratio control, 20 % constant excess supply air volume flow (positive pressure in the room)

	Supply air		Extract air	
	Vmin	Vmax	Vmin	Vmax
Supervisory controller	0 %	100 %	0 %	100 %
VAV Compact Controller	20 %	80 %	0 %	60 %

Reference signal: $Y_{supply_air} = Y_{extract_air} = 25 \%$

Result: $V_{supply_air} = 35 \%$, $V_{extract_air} = 15 \%$

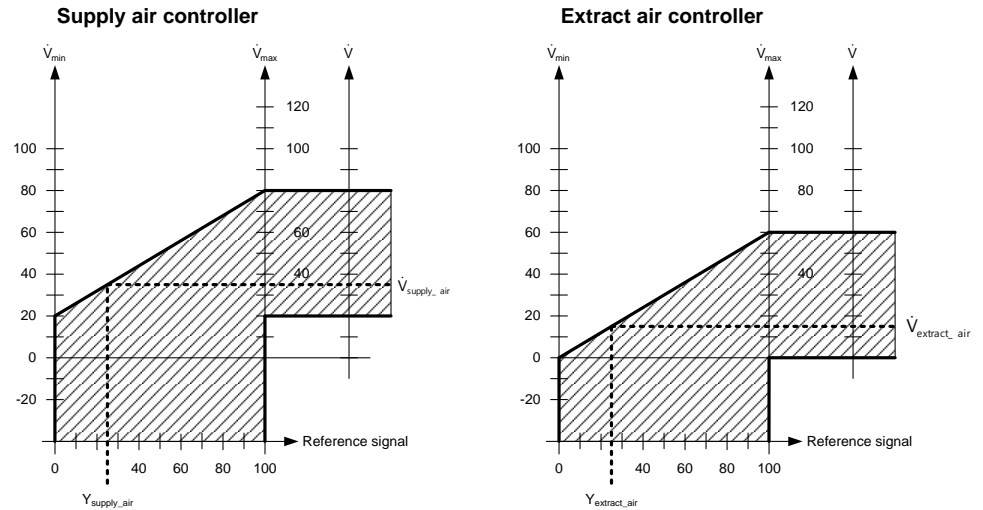

Setting example B3

VAV ratio control, 20 % constant excess extract air volume flow (negative pressure in the room)

	Supply air		Extract air	
	Vmin	Vmax	Vmin	Vmax
Supervisory controller	0 %	100 %	0 %	100 %
VAV Compact Controller	20 %	80 %	40 %	60 %

Reference signal: $Y_{supply_air} = Y_{extract_air} = 25 \%$

Result: $V_{supply_air} = 35 \%$, $V_{extract_air} = 55 \%$

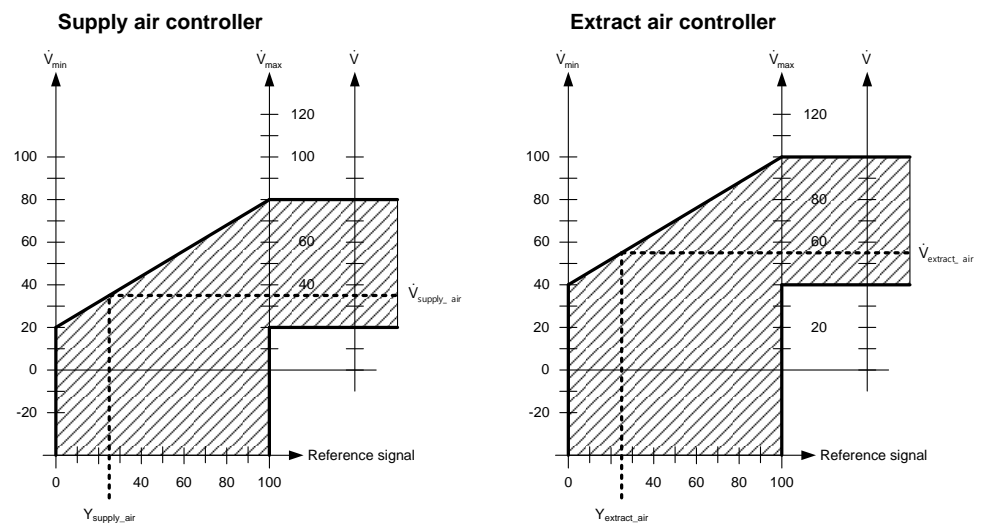

6 Engineering and commissioning

6.1 Fundamentals / environments

Preconditions

For this chapter, sufficient knowledge about Modbus RTU communication and suitable controllers are presupposed.

6.2 Engineering

The basic task of engineering comprises implementation of the data model into a VAV application, especially setpoint and actual values (flow and position) for monitoring and optimization. System limitations of Modbus RTU / RS-485 apply, especially number of devices per segment and cable lengths depending on the baudrate.

The data model is documented as Modbus register list, cf. **9.1** .

6.3 Commissioning

6.3.1 Preconditions

Commissioning preconditions

The beginning of the commissioning phase assumes that all VAV Compact Controllers are mounted according to the mounting instruction [2] as well as all other devices according to their mounting instructions.

All devices must be connected to the power supply and bus cabling. Power supply and bus cabling must be tested, especially the communication between setpoint sender and setpoint receiver.

Commissioning of VAV Compact Controllers consists of two parts:

- Commissioning of the VAV control function (cf. sections **5.1** and **5.1.2**),
- Commissioning of the network integration.

Two basic workflows are supported:

- Full or partial configuration (bus configuration and optionally VAVconfiguration) by a tool (AST20 or ACS941),
- Full or partial configuration over bus, optionally with addressing by push-button.

6.3.2 Workflow 1: Full or partial configuration by tool

When using the AST20 handheld tool or the ACS941 PC tool, all bus parameters and VAV Compact Controller parameters can be set.

- Connect AST20 or ACS941 (using the AST22 interface converter) to the VAV controller and navigate to the bus configuration menu,
- Set bus parameters as desired,
- Optionally make changes on VAV controller parameters in VAV configuration menu.

Note

With AST20, all parameters can be set using the mass configuration function. The bus parameters are included in the mass programming routine. It can be selected that the address is automatically incremented with each programmed VAV controller. ACS941 supports saving and loading of parameter sets.

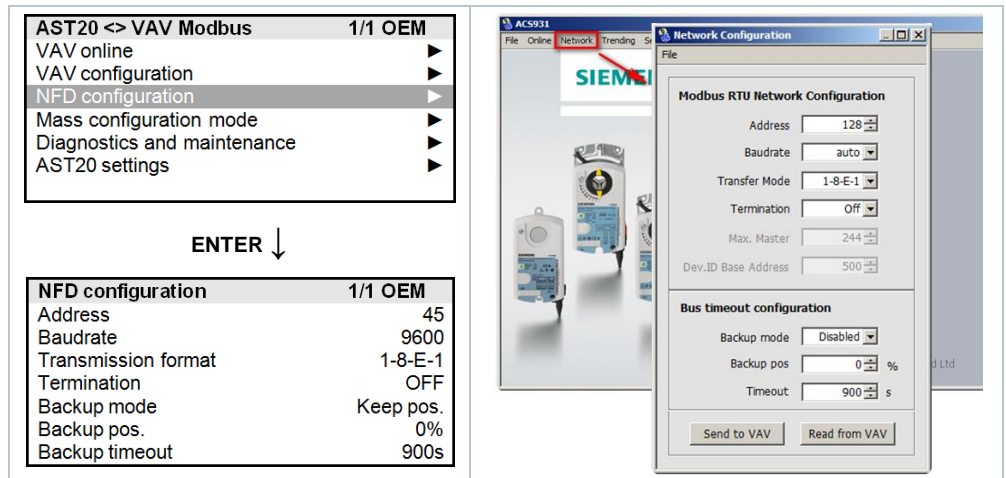

Figure 2: Bus configuration with AST20 (left) and with ACS941 (right)

6.3.3 Workflow 2: Full or partial configuration over bus

The devices can be configured over bus if the pre-commissioning settings allow for a connection between the Modbus master (or programming tool) and peripheral devices (non-conflicting address and matching baudrate / transmission format).

- Full configuration over bus: If the address is unique per segment when powered up, the device can be accessed by the Modbus master (or programming tool) and the address and other parameters can then be set to the definitive values.
- Partial configuration over bus: If the address is not unique per segment when powered up, each device must get a non-conflicting address before connecting it to the bus (e.g. using the push-button addressing method). After addressing all devices, the remaining configuration can be done over the bus using the default settings for baudrate (or auto-baud) and transmission mode for the Modbus master.
- Overwriting the bus configuration over bus uses a timeout. If “1 = Load” is not written into Register 768 within 30 seconds, all values are discarded.

Example

The following table shows bus configuration registers before and after changing them over bus. Attention is to be paid to register 768.

Reg.	Name	Pre-commissioning	New value (ex.)
764	Address	46	12
765	Baudrate	0 = auto	1 = 9600
766	Transmission Mode	0 = 1-8-E-1	3 = 1-8-N-2
767	Termination	0 = Off	0 = Off
768	BusConfigCmd	0 = Ready	1 = Load

7 Safety and EMC optimization

7.1 Safety notes



This section contains general regulations and the regulations for mains and operating voltage. It also provides important information regarding your own safety and that of the entire plant.

 Safety note

The warning triangle to the left means that observance of all relevant regulations and notes is mandatory. If ignored, injury to persons or damage to property may result.

 General regulations

Observe the following regulations during engineering and project execution:

- Electrical and high-voltage directives of the respective country
- Other country-specific regulations
- House installation regulations of the respective country
- Regulations issued by the utility
- Diagrams, cable lists, disposition drawings, specifications and instructions as per the customer or the contractor in charge
- Third-party regulations issued by general contractors or building operators

Safety

The electrical safety of building automation and control systems supplied by Siemens depends primarily on the use of **extra low-voltage with safe isolation from mains voltage**.

SELV, PELV

Depending on the type of extra low-voltage earthing, a distinction is to be made between SELV and PELV as per HD 384, "Electrical plants in buildings":

Unearthed = SELV (Safety Extra Low Voltage)

Earthed = PELV (Protective Extra Low Voltage)

 Earthing of G0 (system neutral)

Observe the following for grounding G0:

As a rule, earthing and non-earthing of G0 is permissible for AC 24 V operating voltage. Decisive are the local regulations and customary procedures. For functional reasons, earthing may be required or not permissible.

Recommendation on earthing G0

AC 24 V systems should always be earthed if this does not contradict the manufacturer's specification. To avoid earth loops, systems with **PELV may only be earthed at one point of the system**, normally by the transformer, unless otherwise specified.

Operating voltage
AC 24 V

Regarding AC 24 V operating voltage, the following regulations must be complied with:

	Regulation
Operating voltage AC 24 V	The operating voltage must comply with the requirements for SELV or PELV: <ul style="list-style-type: none">• Permissible deviation of AC 24 V nominal voltage at the actuators: +/-20 %
Specification on AC 24 V transformers	<ul style="list-style-type: none">• Safety isolating transformers as per EN 61558, with double insulation, designed for 100 % on time to power SELV or PELV circuits• Determine the transformer's output by adding up the power consumption in VA of all actuators used• For efficiency reasons, the power drawn from the transformer should amount to at least 50 % of the nominal load• The transformer's nominal capacity must be at least 25 VA. With smaller transformers, the ratio of no-load voltage and full load voltage becomes unfavorable (> + 20 %)
Fusing of AC 24 V operating voltage	Secondary side of transformer: <ul style="list-style-type: none">• According to the effective load of all connected devices• Line G (system potential) must always be fused• Where required, line G0 (system neutral) also

 Device safety

**Electrical parallel
connection**

Modbus wiring

Note



Warning,
maintenance

7.2 Device-specific regulations

Among other aspects, the safety of devices is ensured by extra low-voltage power supply (AC 24 V) as per **SELV** or **PELV**.

Electrical parallel connection of VAV Compact Controllers provided the required operating voltage tolerance is observed. The **voltage drops of the supply lines** must be taken into consideration.

When planning and installing room controllers and field devices with Modbus RTU connection, the permissible cable lengths, power supply and topologies must be followed. Planning should take into account possible future extensions of a plant.

Mechanical coupling of the devices is not permitted.

Do not open the actuator!

The device is maintenance-free.

Only the manufacturer may carry out any repair work.

7.3 Notes on EMC optimization

Running cable in a duct	Make sure to separate high-interference cables from equipment susceptible to interference.
Cable types	<ul style="list-style-type: none">• Cable causing interference: Motor cables, especially motors used with VSDs, energy cables.• Cables susceptible to interference: Control cables, low-voltage cables, interface cables, LAN cables, digital and analog signal cables.
Cable segregation	<ul style="list-style-type: none">• You can run both types of cable in the same duct, but in different compartments.• If ducting with 3 closed sides and a partition is not available, separate the interference-emitting cables from other cables by a minimum of 150 mm, or route in separate ducting.• Cross high-interference cables with equipment susceptible to interference only at right angles.• If, in exceptional cases, signal and interference-emitting power cables are run in parallel, the risk of interference is high. In that case, limit the cable length of the DC 0...10 V positioning signal line for modulating actuators.

8 Technical data

Power supply		
Operating voltage	G..B181..	AC 24 V ± 20 % (SELV) or AC 24 V class 2 (US)
Frequency		50/60 Hz
Power consumption	at 50 Hz	
	Actuator holds	1 VA/0.5 W
	Actuator rotates	3 VA/2.5 W
Function data		
Positioning time for nominal rotation angle	G..B181..	150 s (50 Hz) 120 s (60 Hz)
Nominal torque	GDB..	5 Nm
	GLB..	10 Nm
Maximum torque	GDB..	< 7 Nm
	GLB..	< 14 Nm
Nom. / max. rotation angle		90° / 95° ± 2°
Direction of rotation	Adjustable by tool or over bus	Clockwise / Counter-clockwise
Connection cables		
Cable length		0.9 m
Power supply	Number of cores and cross-sectional area	2 x 0.75 mm ²
		3 x 0.75 mm ²
Communication		7-pin, grid 2.00 mm
Service interface	Terminal strip	
Communication		
Connection type	Modbus RTU	RS-485, galv. separated
	Number of nodes	Max. 32
	Address range	1..255 (default: 255)
	Transmission formats	1-8-E-1 / 1-8-O-1 / 1-8-N-1 / 1-8-N-2 (default: 1-8-E-1)
	Baudrates (kBaud)	Auto / 9.6 / 19.2 / 38.4 / 57.6 / 76.8 / 115.2 (default: Auto)
	Termination	120 Ω electronically switchable (default: Off)
Environmental conditions		
Applicable standard		IEC 60721-3-x
Operation	Climatic conditions	Class 3K5
	Mounting location	Indoors
	Temperature general	0...50 °C
	Humidity (non condensing)	5...95 % r. h.
Transport	Climatic conditions	Class 2K3
	Temperature	-25...70 °C
	Humidity	5...95 % r. h.
Storage	Climatic conditions	Class 1K3
	Temperature	-5...45 °C
	Humidity	5...95 % r. h.

Degree of protection		
Degree of protection	Degree of protection acc. to EN 60529 (see mounting instruction)	IP54
Safety class	Safety class acc. to EN 60730	III
Directives and Standards		
Product standard	EN 60730-x	
Product family standard	EN 50491-3, EN 50491-5 General requirements for Home and Building Electronic Systems (HBES) and Building Automation and Control Systems (BACS)	
Electromagnetic compatibility (Application)	For residential, commercial and industrial environments	
EU Conformity (CE)	GDB181.1E/MO	GLB181.1E/MO
	A5W00003842 ¹⁾	A5W00000176 ¹⁾
RCM Conformity	GDB181.1E/MO	GLB181.1E/MO
	A5W00003843 ¹⁾	A5W00000177 ¹⁾
UL, cUL	AC 24 V	UL 873 http://ul.com/database
Environmental compatibility		
The product environmental declaration A6V10209938 ¹⁾ contains data on environmentally compatible product design and assessments (RoHS compliance, materials composition, packaging, environmental benefit, disposal).		
Dimensions / Weight		
Weight	Without packaging	0.6 kg
Dimensions		71 x 158 x 61 mm
Suitable drive shafts	Round shaft (with centering element)	8...16 mm (8...10 mm)
	Square shaft	6...12.8 mm
	Min. drive shaft length	30 mm
	Max. shaft hardness	<300 HV
Air volume flow controller		
Type	3-position controller with hysteresis	
V _{max} , adjustable	resolution 1 %	20%...120% (factory setting: 100 %)
V _{min} , adjustable		-20%...100% (factory setting: 0 %)
V _n = f(dp _n), adjustable	resolution 0.01	1.00...3.16 (factory setting: 1.00)
Differential pressure sensor		
	Connection tubes (Interior diameter)	3...8 mm
	Measuring range	0...500 Pa
	Operating range	0...300 Pa
Precision at 23 °C, 966 mbar and optional mounting position	Zero point	± 0.2 Pa
	Amplitude	± 4.5 % of the measured value
	Drift	± 0.1 Pa / Year
	Max. permissible operating pressure	3000 Pa
	Max. permissible overload on one side	3000 Pa

¹⁾ The documents can be downloaded from <http://siemens.com/bt/download>

9 Datapoints and function description

9.1 Device Parameters (ACS931 / ACS941 / AST20)

Parameter	Range	Description	Factory setting
Setpoint	0..100%	Setpoint to VAV controller. 0% → Vmin 100% → Vmax	N/A
Actual position	0..100%	Damper position, depends on setting for position adaptation	N/A
Actual Flow abs.	0..65'535 m ³ /h	Actual volume flow in m ³ /h or l/s	N/A
Actual Flow %	0..100%	Actual volume flow relative to Vnom in %	N/A
Actual pressure	0..300 Pa	Actual differential pressure	N/A
Override control	Open / Close / Sop / Min / Max		
Operating mode	VAV / POS	VAV = Setpoint 0..100% volume flow POS = Setpoint 0..100% damper position	VAV
Opening direction	CW / CCW	Opening direction of air damper	CW
Positioning	Absolute / Adaptive	Adaption of actual opening range to position feedback ¹⁾ Off = No adaptation / mapping 0°...90° → 0..100 % On = Pos. adaptation / mapping e.g. 0°...60° → 0..100 %	Absolute
Vmin	-20..100%	Minimum air volume flow	0 %
Vmax	20..120%	Maximum air volume flow	100 %
Vnom	0..65'535 m ³ /h	Nominal air volume flow ²⁾	100 m ³ /h
Vn (Coefficient)	1..3.16	Characteristic value for the VAV box; set by the OEM	1.00
dpnom	30..300 Pa	Nominal differential pressure, corresponds to Vn	300 Pa
Altitude asl.	0..5000m in 500m steps	Altitude level correction, select n*500m value closest to altitude of installation	500 meters
Unit vol. flow	m ³ /h / l/s / cfm	Unit in which the volume flow is displayed	m ³ /h
Unit Vmin & Vmax	%, m ³ /h or l/s	Unit in which Vmin / Vmax are entered	%
Address	1..245	RS-485 bus address	255
Baudrate	Auto, 9600... 115'200	RS-485 baudrate	Auto
Transmission Format	1-8-E-1 / 1-8-O-1 / 1-8-N-1 / 1-8-N-2	Start- / Stop-Bit, Parity	1-8-E-1
Termination	Off / On	RS-485 bus termination, electronically switchable	Off

¹⁾ Adaptive positioning must not be activated while the actuator is mechanically jammed

²⁾ Value used for displaying / not used for volume flow control loop

9.2 Modbus Registers

For detailed descriptions of the function behind a certain item, e.g. “how does RemoteFactoryReset in register 256 work”, please cf. section 9.3.

9.2.1 Process values

Reg.	Name	R/W	Unit	Scaling	Range / enumeration
Process Values					
1	Setpoint	RW	%	0.01	0..100
2	Override control	RW	--	--	0 = Off / 1 = Open / 2 = Close 3 = Stop / 4 = GoToMin 5 = GoToMax
3	Actual position	R	%	0.01	0..100
4	Actual Flow [rel.]	R	%	0.01	0..120
5	Actual Flow [abs.]	R	m ³ /h / l/s	1	0..60000
6	Actual Pressure	R	Pa	0.1	0..500
256	Command	RW	--		0 = Ready 1 = Reserved 2 = Self-test 3 = ReInitDevice 4 = RemoteFactoryReset

9.2.2 Parameters

Reg.	Name	R/W	Unit	Scaling	Range / enumeration
Parameters					
257	Opening direction	RW	--	--	0 = CW / 1 = CCW
258	Adaptive Mode	RW	--	--	0 = Off / 1 = On
259	Operating Mode	RW	--	--	0 = VAV / 1 = POS
260	MinPosition	RW	%	0.01	0..100
261	MaxPosition	RW	%	0.01	0..100
262	Actuator Running Time	R	s	1	150
385	Vnom	RW	m ³ /h	0.0001	0..429496.7295
386	Vmin	RW	%	0.01	-20..100
387	Vmax	RW	%	0.01	0..120
388	Altitude Level	RW	m	1	0..5000
389	Unit Switch	RW	--	--	0 = m ³ /h 1 = l/s
513	Backup Mode	RW	--	--	0 = Go to BackupPosition 1 = Keep last position 2 = Disabled
514	Backup Position	RW	%	0.01	0..100
515	Backup Timeout	RW	s	1	0..65535
764	Modbus Address	RW	--	--	1..247 / 255 = “unassigned”
765	Baudrate	RW	--	--	0 = auto / 1 = 9600 / 2 = 19200 3 = 38400 / 4 = 57600 / 5 = 76800 6 = 115200
766	Transmission Format	RW	--	--	0 = 1-8-E-1 / 1 = 1-8-O-1 2 = 1-8-N-1 / 3 = 1-8-N-2
767	Bus Termination	RW	--	--	0 = Off / 1 = On
768	Bus Conf. Command		--	--	0 = Ready / 1 = Load / 2 = Discard
769	Status	R	--	--	See below

9.2.3 Device information

Reg.	Name	R/W	Value	Example																				
Device information																								
1281	Factory Index	R	Two bytes, each coding an ASCII char.	00 5A → 00 "Z" Device is of Series "Z"																				
1282	Factory Date HWord	R	Two bytes, the lower coding the Year (hex)	Read 1282 → 000F Read 1283 → 0418																				
1283	Factory Date LWord	R	High byte: coding the month (hex) Low byte: coding the day (hex)	<table border="1"> <thead> <tr> <th></th> <th colspan="2">HWord</th> <th colspan="2">LWord</th> </tr> <tr> <th></th> <th>--</th> <th>YY</th> <th>MM</th> <th>DD</th> </tr> </thead> <tbody> <tr> <td>Hex</td> <td>00</td> <td>0F</td> <td>04</td> <td>18</td> </tr> <tr> <td>Dec</td> <td>00</td> <td>15</td> <td>04</td> <td>24</td> </tr> </tbody> </table> → Device was manufactured 24 April, 2015		HWord		LWord			--	YY	MM	DD	Hex	00	0F	04	18	Dec	00	15	04	24
	HWord		LWord																					
	--	YY	MM	DD																				
Hex	00	0F	04	18																				
Dec	00	15	04	24																				
1284	Factory SeqNo HWord	R	Hword + LWord = HEX-representation of Sequence number:	Read 1284 → 000A																				
1285	Factory SeqNo HWord	R		Read 1285 → A206 AA206(hex) → 696838 (dec) → Device has sequence number 696838																				
1409	TypeASN [Char_16..1]	R	Each register: Two bytes, each coding an ASCII char. ASN is coded beginning with reg. 1409	Example:																				
1410	TypeASN			0x47 44 = GD																				
1411	TypeASN			0x42 31 = B1																				
1412	TypeASN			0x38 31 = 81																				
1413	TypeASN			0x2E 31 = .1																				
1414	TypeASN			0x45 2F = E/ 0x4D 4F= MO → ASN is GDB181.1E/MO																				

9.2.4 Status register

The status register indicates the True/False state of the listed items.

Status			
Bit 00	1 = Local override	Bit 06	1 = Adaptation run done
Bit 01	1 = Backup mode active	Bit 07	1 = Adaptation run in progress
Bit 02	1 = Sensor comm. fault	Bit 08	1 = Reserved
Bit 03	1 = Sensor tubes crossed	Bit 09	1 = Reserved
Bit 04	1 = Device jammed	Bit 10	1 = Self-test passed
Bit 05	1 = Nom. lifetime exceeded	Bit 11	1 = Invalid configuration

9.2.5 Supported function codes

The following function codes are supported. For function code 16 "Write multiple register", the limitation of max. 120 register within one message applies.

Function codes	
03 (0x03)	Read Holding Registers
04 (0x04)	Read Input Registers
06 (0x06)	Write Single Register
16 (0x10)	Write Multiple registers

9.3 Parameter and function description

9.3.1 Vnom (nominal volume flow) [m³/h or l/s]

VAV boxes are ordered through an OEM according to the required nominal volume flow (Vnom) and min. / max. volume flow settings (Vmin / Vmax). The maximum volume flow for ventilating a room / zone can't be higher than the nominal volume flow.

9.3.2 Vmin / Vmax (minimum / maximum volume flow) [%]

These values limit the nominal volume flow by multiplying with Vnom. Their effect is described in chapter 5.

9.3.3 Elevation above sea level [m]

This value enhances the accuracy of the differential pressure sensor to compensate for the air density decreasing with increasing altitude. It can be set in 500m steps, so for a given building the setting closest to the actual altitude is to be used.

Example: Altitude of building: 420m a.s.l. → use setting "500m"

9.3.4 Override control

The actuator can be operated in override control for checking / maintenance purposes or system-wide functions (e.g. night-cooling).

9.3.4.1 Local override

The actuator enters this state when a service tool is connected by the service interface (PPS2). Available commands:

- Open / Close (depends on opening direction)
- Min / Max (depends on Min/Max settings)
- Stop

If the actuator is in backup mode, it will be controllable in local override but resume the backup mode

- when the service tool is disconnected,
- when the local override timeout is exceeded, or
- when the override control is set to "off".

Timeout is 10s after the last read or write access.

9.3.4.2 Remote override

The actuator enters this state when an override command is sent over the bus. The override control is available as Modbus register with the following enumeration:

- Open / Close (depends on opening direction)
- Min / Max (depends on Min/Max settings)
- Stop

9.3.5 Adaptive positioning

9.3.5.1 Function

For VAV boxes and air dampers with an opening range smaller than $0...90^\circ$, the position setpoint and feedback signal can be adapted to $0...100\%$.

- Adaptive positioning **off**: Position control / feedback relative to $0^\circ...90^\circ$,
→Example: $0^\circ \rightarrow 0\%$, $18^\circ \rightarrow 20\%$, $81^\circ \rightarrow 90\%$ etc.
- Adaptive positioning **on**: Position control / feedback relative to the *mechanical* lower / upper endstops which are determined in an adaptation run.
→Example: The lower endstop is at 15° and the upper endstop is at 60°
 $15^\circ \rightarrow 0\%$, $45^\circ \rightarrow 66\%$, $60^\circ \rightarrow 100\%$ etc.

9.3.5.1 Activation and deactivation

- Immediately after changing the parameter “Adaptive positioning” from **off** to **on**, an adaptation run is performed. During the adaptation run, the actuator drives to both mechanical end stops and stores these positions persistently as 0% and 100% reference points. Cf. diagram below for a detailed description.

Important: Adaptation must not be activated while a device jam is present!

- Adaptive positioning can be (de-)activated with the service interface (ACS931 / ACS941 / AST20) or over the bus.
- If adaptive positioning is deactivated *before the adaptation run has finished*, the adaptation run will stop immediately, and no end stops will be stored.
- In case of a power reset during the adaptation run, the adaptation run will restart automatically after the power supply has been restored.
- To trigger the adaptation run again the adaptive positioning must be turned off and on again.
- A manual gear disengagement of less than 20 seconds doesn't impact the adaptation run or its result.

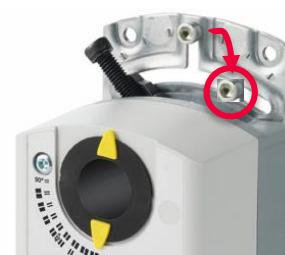
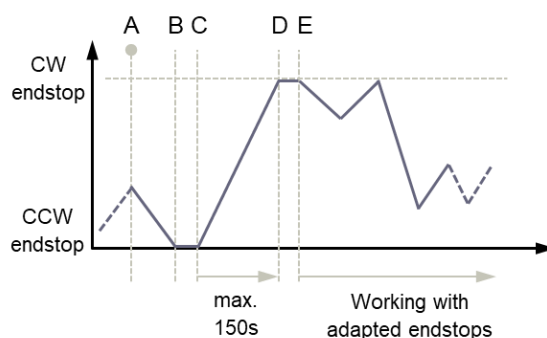

- Adaptive positioning is set to on. Actuator drives to the counter-clockwise (CCW) endstop.
- CCW endstop is reached.
- If the position remains constant for ca. 10 seconds, it is stored non-volatile. The actuator then drives to the clockwise (CW) endstop.
- CW endstop is reached.
- If the position remains constant for ca. 10 seconds, it is stored non-volatile. The actuator now follows the adapted setpoint.

Example: Stop screw set at ~75% of the full range

Note: If the adaptation run starts close to the CW endstop, it can take up to 5.5 minutes for completion (2x 150s + waiting times in the endstops).

9.3.6 Device Jam

- If an actuator can't reach a target position due to a mechanical failure or an angle limitation screw, a device jam alarm is thrown.
- The device jam is detected ca. 30s after the effective mechanical end stop (when lying before the target end stop) is reached.
- After 30..35s the motor stops and the steady red LED indicates the device jam alarm until the blockage is physically removed.
- Initiating an adaptation run while the actuator is jammed does not resolve the alarm by using the mechanical end stop as reference position.

9.3.7 Operating mode

The operating mode determines whether the setpoint signal (0...100 %) from the supervisory controller is interpreted as volume flow control or as air damper position control.

If used as damper control signal, the actual values from the flow sensor remain available. This allows to implement the flow control loop in an external controller.

9.3.8 Backup mode

In case the communication to the controller is lost, the device can be configured to go into a defined state. This function utilizes a watchdog which monitors setpoint write access over the bus.

Default setting of this backup mode is "Off", i.e. in case of a communication loss, the device controls to the last received setpoint until an updated setpoint is received.

If the backup mode is enabled, it can be configured as follows:

- go to a position predefined by the parameter "Backup position"
- keep current position without controlling to the last received setpoint.

When the device is in backup mode and receives a setpoint over the bus again, it wakes up and performs control to the setpoint again.

9.3.9 Restarting the device

Restarting is possible by:

- Power-reset (switching operating voltage off and on) or
- by "RelnitDevice" command.

Effect of restart: Device re-initializes and sets all process values to defaults.

9.3.10 Reset behavior

The actuator supports the following re-initialization / reset behavior:

- Local reset by push-button: cf. section 2.4.2
- Tool-reset, cf. section 5.1.2
- Remote reset: Using “RemoteFactoryReset” command.

Effect of reset:

- Process values: set to ex-works default values.
- Parameters:
 - Application and actuator parameters are set to factory or OEM defaults,
 - Network parameters are reset only in case of local reset, not by remote reset (otherwise loss of communication).
- Counters are not reset.
- Status flags are not reset.
- Device Information and Factory Data are not reset.

9.3.11 Self-test

The actuator supports a self-test. When triggered, the self-test runs the actuator to the detected limits and sets the flags in register 769 according to the result (bit 09 = 1 → “failed” or bit 10 = 1 → “passed”).

- The self-test is not passed when the limits were not reached from the lower end (results in jam).
- If the limits can be exceeded, the self-test is not evaluated as failed.

9.3.12 Configuration check

The actuator supports a basic configuration check for the relation between Vmin and Vmax: Vmax must be greater than Vmin, otherwise this is regarded an invalid configuration. Tolerance level is 2% difference.

In case of an invalid configuration, the LED blinks red and the flag “invalid configuration” in the status register (bit 11 in reg. 769) is set to “1”.

9.4 Object and function priorities

Prio	State	Behavior after power reset
1	Manual gear disengagement	Independent
2	Adaptation run	Will be restarted all over ¹⁾
3	Self-test run (status)	Will be cancelled (reset) ¹⁾
4	Local override control	Will be reset
5	Remote override control	Will be reset
6	Setpoint	Will be reset
7	Backup mode	Remains unchanged

¹⁾ Will be overridden by Backup mode.

10 Environmental compatibility and disposal

General notes



Environmental declaration

The products were developed and manufactured by using environmentally compatible materials and by complying with environmental standards. For disposal, please remember the following at the end of product life or in case of defects:

- The products consist of plastics and materials such as steel, ferrite magnetic core, etc. and must not be disposed of together with domestic waste; this applies particularly to the printed circuit boards.
See also European Directive 2012/19/EU
- As a rule, dispose of all waste in an environmentally compatible manner and in accordance with the latest developments in environmental, recycling and disposal techniques.
Local and currently valid legislation must be observed.
- The aim is to achieve maximum recyclability of the basic materials while ensuring minimum strain on the environment. To do this, note the various material and disposal notes printed on specific components.

The Environmental Declarations on these products contain detailed information about the materials and volumes used. If you need a copy, please contact your Siemens sales office.

Issued by
Siemens Switzerland Ltd
Smart Infrastructure
Global Headquarters
Theilerstrasse 1a
6300 Zug
Switzerland
Tel. +41 58-724 24 24
www.siemens.com/buildingtechnologies

© Siemens Switzerland Ltd, 2015
Technical specifications and availability subject to change without notice.